



KINDRED

FOOD WASTE DISPOSER

KWD50C1-EZ

- ✓ Continuous feed
- ✓ 1/2 Horsepower motor
- ✓ High Speed 2600 RPM permanent magnet motor
- ✓ EZ mount installation system
- ✓ Stainless steel grinding components
- ✓ Sound insulated shell
- ✓ Safe for properly sized septic tanks
- ✓ For use with 110-120 volts/60hz electrical only

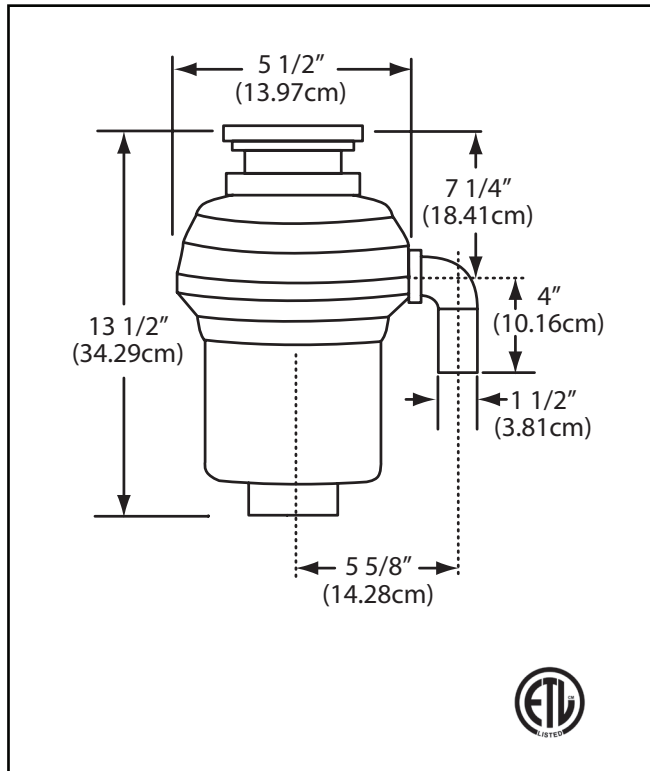

TECHNICAL FEATURES

MOTOR HORSEPOWER	1/2 HP
MOTOR SPEED RPM	2600
VOLTAGE	110 - 120
HZ	60
CURRENT-AMPS	4.5
MOTOR TYPE	Permanent Magnet
POWER CORD	Factory Installed
SINK FLANGE	Stainless Steel
STOPPER	Positive Seal
WASTE ELBOW	ABS
FEED	Continuous
GRIND RING	Stainless Steel
SWIVEL IMPELLERS	Cast Stainless Steel
TURNTABLE	Stainless Steel
HOPPER	Polycarbonate 940
GRINDING CHAMBER	Corrosion Proof Glass Filled Polyester
BEARINGS	Permanently Lubricated; Sleeve Type
OVERLOAD PROTECTOR	Manual reset type
SOUND SHELL	Full foam insulated
SHIPPING WEIGHT	10.6 LBS (4.8KG)
WARRANTY	5 YEARS
COUNTRY OF ORIGIN	CHINA